



ADVANCED LABEL TECHNOLOGY

English

TFE 350

Guillotine machine



Features

Guillotine and slitting machine for labels and other materials in roll.

The machine can work in-line or off-line and it is operated by an user friendly touch screen control panel. It is configurable with output conveyor belt, stacker or chute.

The cutting can be adjusted according to the length, the number of labels or the printing marks.

The TFE350 is extremely precise thanks to the LPS centring system, with which it is possible to accurately correct with centesimal precision the gap errors detected on the pre-printed materials.

Technical Data

Productivity: up to 18.000 pieces / hour

Productivity (A4 format): 15.000 pieces / hour

Power supply: 230 v - 50/60 hz

Web width: 360 mm - (14 in)

Applications

Guillotine cutting

Scissor blade slitting

Front and rear pressure blade slitting

Double crossing cut

Conveyor belt

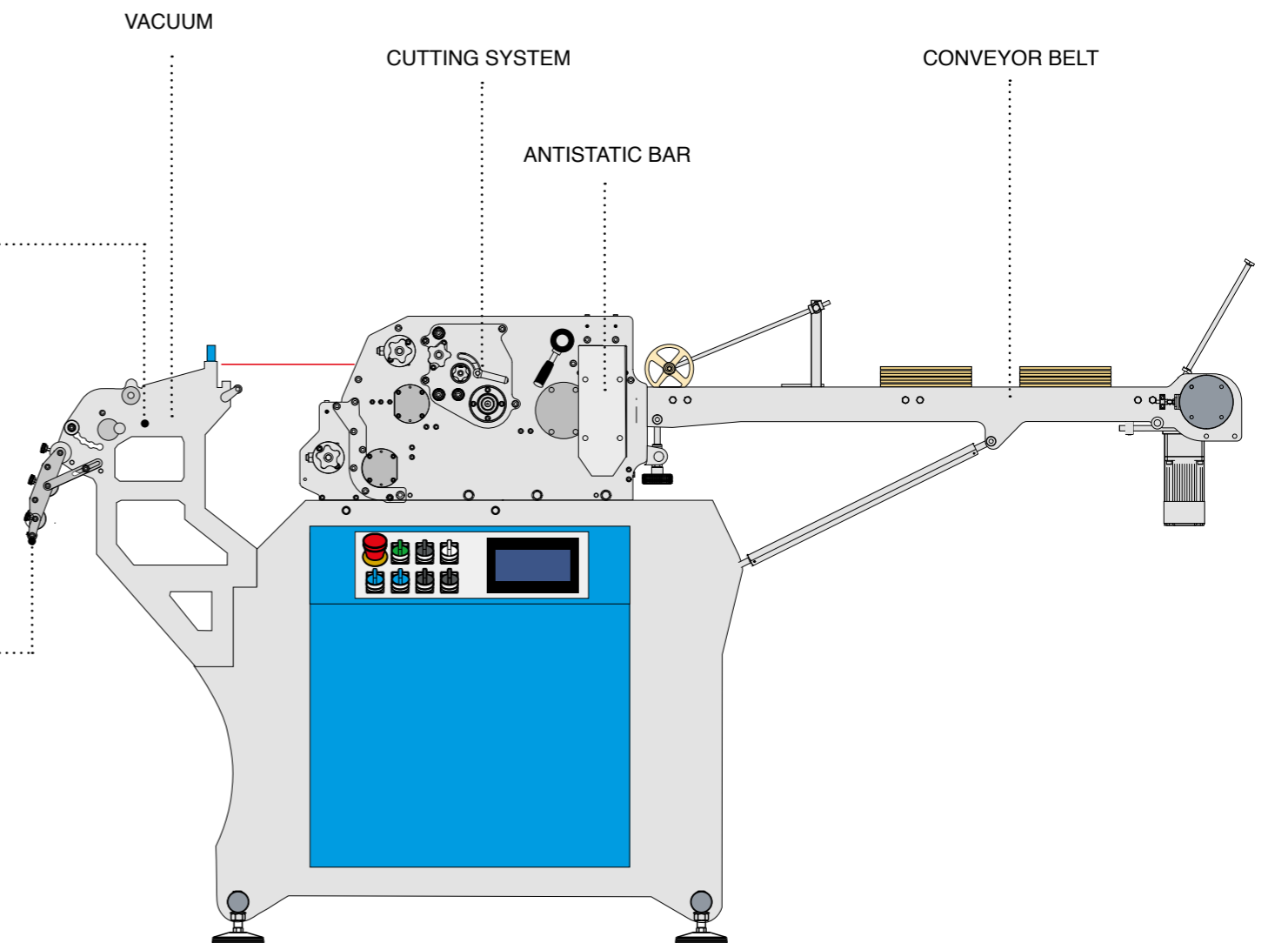
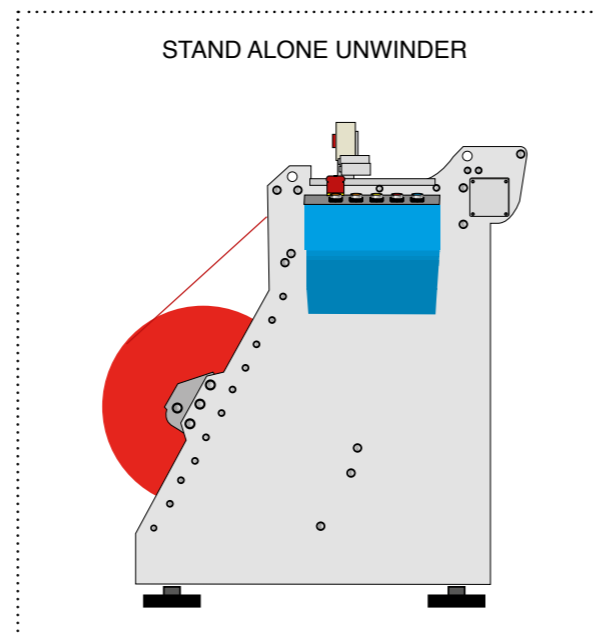
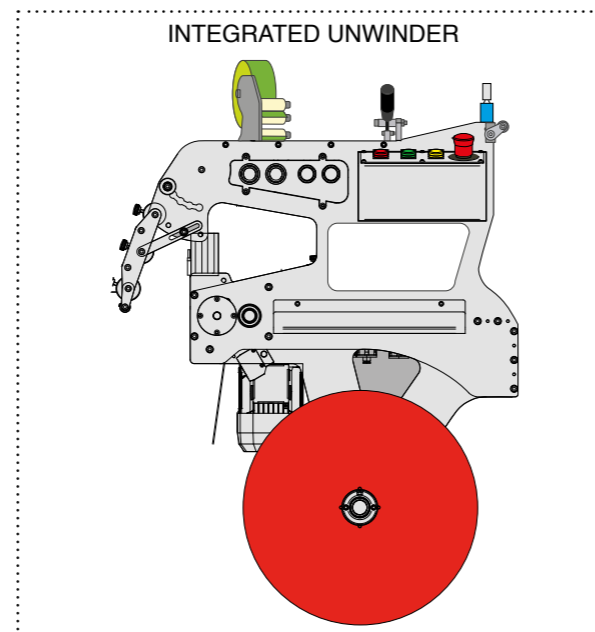



CARTES s.r.l. - 2, Via Michelangelo - 46024 MOGLIA (MANTOVA) ITALY
Tel. + 39 0376 511 511 Fax + 39 0376 55 77 55
www.cartes.it - info@cartes.it